

# SHEAR SPECIFICATIONS

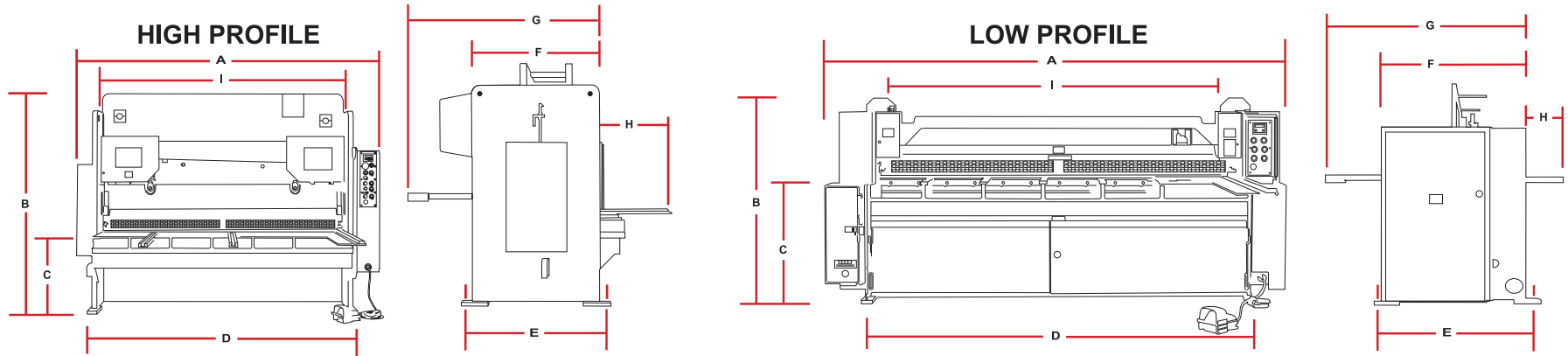

All dimensions are in inches unless otherwise noted.  
(To convert to centimeters multiply by 2.54)

Engineering data and dimensions are subject to change without notice due to continuing product development.

Foundation plans are available upon request.

10 GA, 3/16", and 1/4", machines will be low profile, unless it is a gap type machine.

\*Larger motor sizes are available. To convert from horsepower to KW, multiply by 0.746

\*\*ESTIMATED WEIGHTS. The weight of your machine may vary from the estimated weight listed here. Weights may vary according to options included.

\*\*\*1 x 12" has separate power unit.

**Please Note: ALL measurements and weights may vary from the figures given in this Specification Chart.**

HP	AMPS	
	208/230	460
5	14	7
10	28	14
15	39.6	19.3
20	52	26
25	68	34
30	80	40
40	104	52

A Overall Length	D Anchor Bolt Dimension/Length	G Machine w/ Backgauge	J Rake Angle per Rated Capacity
B Overall Height	E Anchor Bolt Dimension/Width	H Squaring Arm Length (4' Std.)	K Strokes Per Minute
C Table Height	F End Plate Width	I Knife Length	L Number of Holddown Pins

MODEL	KNIVES	H.P. *	A	B	C	D	E	F	G	H	I	J	K	L	Wt.**
2'-125	½ x 2	10	48	55	32	33	36	30	74	30	28	1/4	35	6	3,400
4'-125	1x3	10	75	55	32	52	36	30	74	30	52	1/4	35	13	4,500
5'-125	½ x 2	10	85	55	32	64	36	30	74	30	62	1/4	35	11	4,800
6'-125	1x3	10	97	55	32	76	36	30	74	30	76	1/4	35	13	6,500
8'-125	1x3	10	121	55	32	100	36	30	74	30	100	1/4	32	15	6,800
10'-125	1x3	10	145	55	32	124	36	30	74	30	124	1/4	30	19	9,100
12'-125	1x3	10	169	60	32	148	36	30	74	30	148	1/4	26	21	14,000
14'-125	1x3	10	193	60	32	172	36	30	74	30	172	1/4	24	23	18,000
16'-125	1x3	10	217	60	32	196	36	30	74	30	196	1/4	22	25	20,000
2'-1875*	½ x 2	10	48	64	32	40	36	30	74	30	28	1/4	35	6	3,500
4'-1875	1x3	10	75	55	32	52	36	30	74	30	52	1/4	35	13	4,500
5'-1875	½ x 2	10	85	55	32	64	36	30	74	30	62	1/4	35	11	4,800
6'-1875	1x3	10	97	55	32	76	36	30	74	30	76	1/4	35	13	6,700
8'-1875	1x3	10	121	55	32	100	36	30	74	30	100	1/4	32	15	7,000
10'-1875	1x3	10	145	55	32	124	36	30	74	30	124	1/4	30	19	9,100
12'-1875	1x3	10	169	60	32	148	36	30	74	30	148	1/4	26	21	15,000
14'-1875	1x3	10	193	60	32	172	36	30	74	30	172	1/4	24	23	19,000
16'-1875	1x3	10	217	60	32	196	36	30	74	30	196	1/4	23	25	20,500
4'-250	1x4	15	84	61	32	55	50 ½	44	76	35	52	1/4	20	13	7,500
6'-250	1x4	15	108	61	32	79	50 ½	44	76	35	76	1/4	19	13	8,400
8'-250	1x4	15	132	61	32	103	50 ½	44	76	35	100	1/4	17	15	9,800
10'-250	1x4	15	156	61	32	127	50 ½	44	76	35	124	1/4	15	19	12,500
12'-250	1x4	15	180	61	32	151	50 ½	44	76	35	148	1/4	13	21	14,000
14'-250	1x4	15	204	61	32	175	50 ½	44	76	35	172	1/4	11	23	20,000
16'-250	1x4	15	228	61	32	199	50 ½	44	76	35	196	1/4	10	25	22,000
2'-375*	½ x 2	15	48	64	38	40	35	34	80	10	28	1/4	12	6	4,400
4'-375	1x4	20	75 ½	84	32	56	55	48	80	24	52	3/8	17	11	11,000
6'-375	1x4	20	99 ½	84	32	80	55	48	80	24	76	3/8	17	14	15,100
8'-375	1x4	20	123 ½	84	32	104	55	48	80	24	100	3/8	13	14	18,500
10'-375	1x4	20	147 ½	84	32	128	55	48	80	24	124	3/8	11	17	21,000
12'-375	1x4	20	171 ½	84	32	152	55	48	80	24	148	3/8	10	20	24,000
14'-375	1x4	20	195 ½	84	32	176	55	48	80	24	172	3/8	9	23	27,000
4'-500	1x4	20	75 ½	84	32	56	55	48	80	24	52	1/2	13	11	13,800
6'-500	1x4	20	99 ½	84	32	80	55	48	80	24	76	1/2	13	14	17,000
8'-500	1x4	20	123 ½	84	32	104	55	48	80	24	100	1/2	10	14	22,500
10'-500	1x4	20	147 ½	84	32	128	55	48	80	24	124	1/2	9	17	28,000
12'-500	1x4	20	171 ½	84	32	152	55	48	80	24	148	1/2	8	20	32,000
10'-625	1x4	30	147 ½	84	32	128	55	48	80	24	124	1/2	9	17	28,000
12'-625	1x4	30	171 ½	84	32	152	55	48	80	24	148	1/2	8	20	32,000
4'-750	1 1/8x5	40	77	97	32	56	55	48	80	32	52	5/8	11	11	15,700
6'-750	1 1/8x5	40	101	97	32	80	55	48	80	32	76	5/8	10	14	22,000
8'-750	1 1/8x5	40	125	97	32	104	55	48	80	32	100	5/8	8	14	27,000
10'-750	1 1/8x5	40	149	97	32	128	55	48	80	32	124	5/8	7	17	31,000
12'-750	1 1/8x5	40	173	97	32	152	55	48	80	32	148	5/8	6	20	35,000
1"-12"	1/4	20	48	64	38	128	55	36	80***	12	18	1/4	12	8	TBA



## TECHNICAL SPECIFICATIONS

**Frame and Base:** Side frames are welded to the table base assembly as a closed end type, which is standard. With the gap end option, base of end housings have provisions to anchor machines to flat surface. The upper knife is manufactured with means of adjustment for obtaining and maintaining clearance adjustment between upper and lower knives. Mounting holes in the feet allow for firm attachment to the floor and leveling of the machine.

**Table:** The table is constructed of fabricated steel, which is flat to  $\pm 0.005$  inch per linear foot. The standard table is solid for the first 24 inches on the right side with support beams 16 inches on center for balance of machine.

**Options:**

1. Solid table top bolt on segments
2. Machined bed
3. Hand slots (optional where specified)
4. Ball transfers (available in any of the table top patterns - open, bolt on segments or machined solid table top)

**Ram:** The ram is guided through the shearing stroke by a bronze slide assembly and a steel assembly. The assemblies guide the ram on a vertical shearing plane with 2 angular degrees off the shearing plane of the stationary knife. The bronze slides have a large surface area to dissipate pressure per square inch. The PSI is low in comparison to machines that use swings or have many pins and little area to dissipate the pressure. Optional non-metallic slide assemblies are available to replace bronze.

**Hydraulic System:** The hydraulic system is designed for the capacity of the rated machine to JIC standards. The hydraulic system has safety overload protection. Hoses, tubes and fittings are rated at no less than 150% of the rated working pressure.

**Hydraulic Cylinder Drive:** There are two direct acting hydraulic cylinders for directing the ram. The hydraulic cylinder drive has double acting pistons and ball sockets for self-aligning joints.

**Hydraulic Hold down System:** On the 1/8" (10 GA), 3/16" and 1/4" machines the hydraulic self-compensating spring plunger bar assembly has plungers every 4 inches for the first 24 inches and plungers 8 inches on center for the remainder of the bar. On 3/8", 1/2", 5/8", 3/4", and 1" machines, the plungers are spread every 5 inches for the first 24 inches and plungers 8 1/2 inches on center for the remainder of the bar. The hydraulic holddown system automatically secures the workpiece during ram down-stroke and releases on return stroke. Optional independent holddown control is available. Refer to chart for the number of plungers.

**Reservoir:** The reservoir features combination level and temperature gauges and a cleanable filter system capable of removing particles 10 microns in size.

**Shear Knife:** Our knives are made of a shock resistant grade of modified high carbon, high chrome with four edges. Harder grade of high carbon, high chrome is available.

**Controls:** Controls include:

1. Pull to start, push to stop.
2. Jog (inch)- Single stroke – run  
Optional: Continuous stroke
3. Single palm button for stroke
4. Backgauge controls:
  - forward/reverse
  - variable speed
5. Emergency up-switch



**Rake Angle and Rake Angle Adjustment:**

Power rake angle adjustment is standard. Angle is maintained throughout cutting cycle, when rake angle is adjusted to require angle. Refer to chart.

Increased adjustable rake angle is standard on all machines to allow for cutting of harder and heavier material.

**Electrical System:** The electrical systems meets NFPA 79 standards. All machines have disconnect switches, magnetic starters, 110/120v controls, 208-230/460v 3 phase, others optional.

**Motors:** Motors are open drip with sealed and permanent lubricated bearings.

**Control Circuit Voltage:** Control voltage is 110/120v supplied by a transformer.

**Backgauge:** 36" power operated backgauge is standard. Controls are located on front of the machine. 5 Station NC "GO-TO" Positioner is standard.

**Front Support Arms (Optional):** Front support arms are available with or without scales.

**Squaring Gauge:** 4' squaring arm on right-hand side with scale is standard. Left-hand squaring arm and longer gauges are optional.

**Angle Gauge (Optional):** Angle gauge marked in 1/2° increments.

**Light Beam Gauge (Standard):**

Shearing gauge utilizes light beam shadow as the shearing line.

**Capacity:** Machines are based on 80,000 pounds tensile. Other options are available upon request.

Convert Feet to Millimeters Multiply By 304.8	
2'	609.6 mm
4'	1219.8 mm
5'	1524.0 mm
6'	1828.8 mm
8'	2438.4 mm
10'	3048.2 mm
12'	3657.6 mm
14'	4267.2 mm

Convert Inches to Millimeters Multiply By 25.4		
1/8"	0.125	3.18 mm
3/16"	0.188	4.77 mm
1/4"	0.250	6.35 mm
3/8"	0.375	9.53 mm
1/2"	0.500	12.7 mm
5/8"	0.625	15.88 mm
3/4"	0.750	19.05 mm
1"	1.000	25.4 mm
1 1/4"	1.250	31.75 mm

**Shearing Accuracy:** The Betenbender Hydraulic Shears will meet or exceed shearing accuracy of material ranging up to the full width capacity of the machine to precision tolerances. The width of the sheared workpiece shall be within ±0.005 inch of the backgauge settings.

**Safety Features:** The Betenbender Hydraulic Shears are built to meet ANSI B11.4 standards. Some of the safety features of the Betenbender Shears are:

- Finger Guard for holddown w/ safety switch
- 110/120v control
- Guarded foot pedal
- Warning signs, safety markings & covers
- Electronics meet NFPA 79 standards
- Central systems provide the operator with complete control to stop & reverse the ram by simply releasing the control
- For multiple operators, a separate control for each person, can be provided within reach of the machine
- Emergency up-switch on control panel

**Specifications are subject to change without notice.**

Compliance with OSHA requirements is the legal responsibility of the user and is subject to local inspectors' interpretation of existing standards.

**Betenbender Shears are built to meet ANSI B11.4 standards**