

# BETENBENDER Manufacturing, Inc.

5806 Quality Ridge Road • PO Box 140  
 Coggon, Iowa 52218  
 Ph: (319) 435-2378 • Fax: (319) 435-2561  
 www.betenbender.com  
 E-mail: sales@betenbender.com



The following pages illustrate General Purpose Punches and Dies used by the fabricating industry.

Power Brake Tools are made of high chrome-carbon die steel of the work hardening type with initial hardness throughout of Rockwell "C" 27-30 (Brinell 270).

The tongue (Fig. A) is generally considered standard. However, we do recommend a Safety Tongue (Fig. B) where weight is a factor; or the punch is sectioned; or when you have downward stripping pressure, i.e., Channel Forming Dies. Unless specified a Standard Tongue will be supplied. All dimensions are nominal and subject to minor changes.

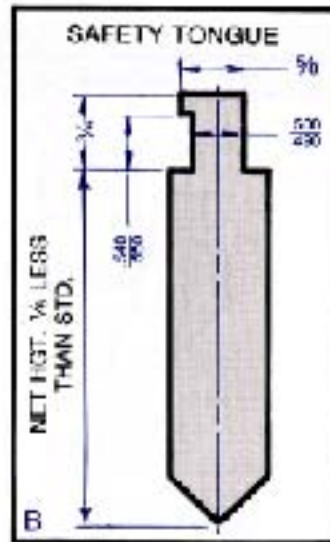
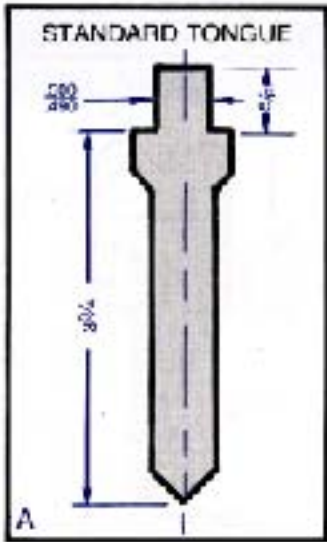

## BOTTOMING PUNCHES 90° ANGLES

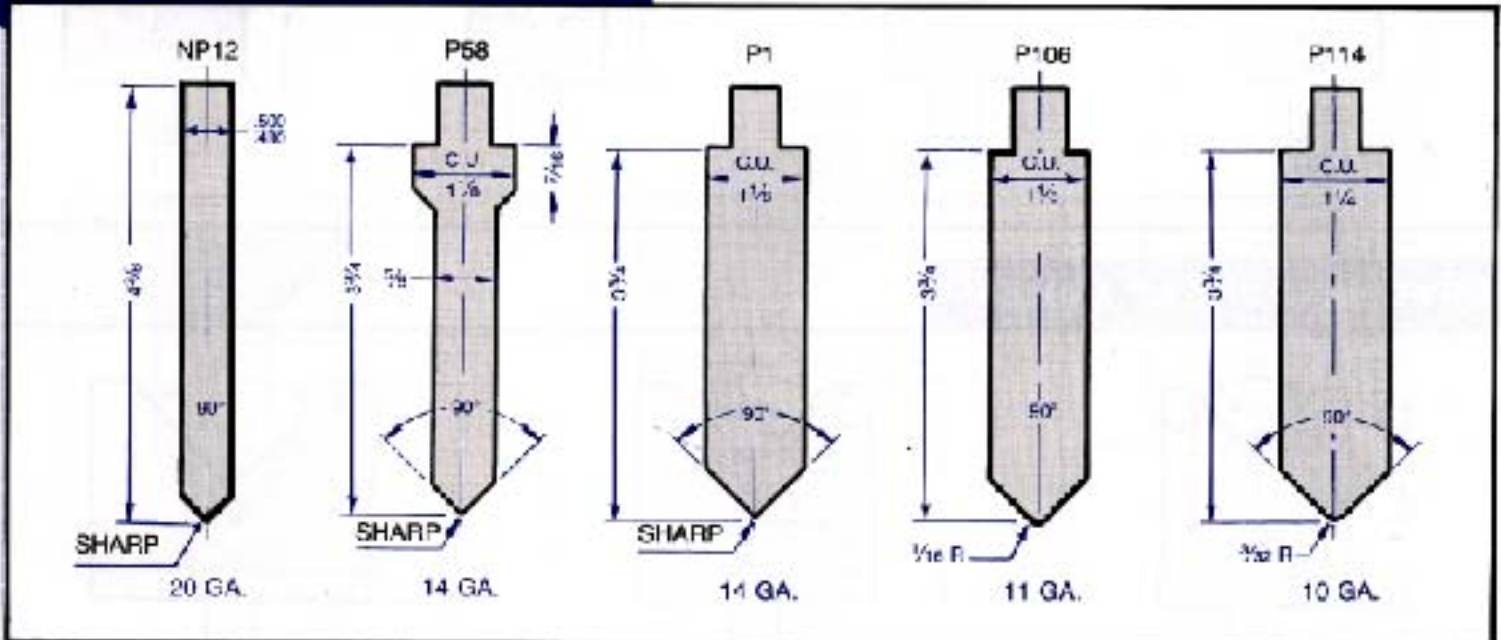

## AIR FORMING PUNCHES 85° ANGLES

